

Installation instructions

for NoFrost combined refrigerator-freezers

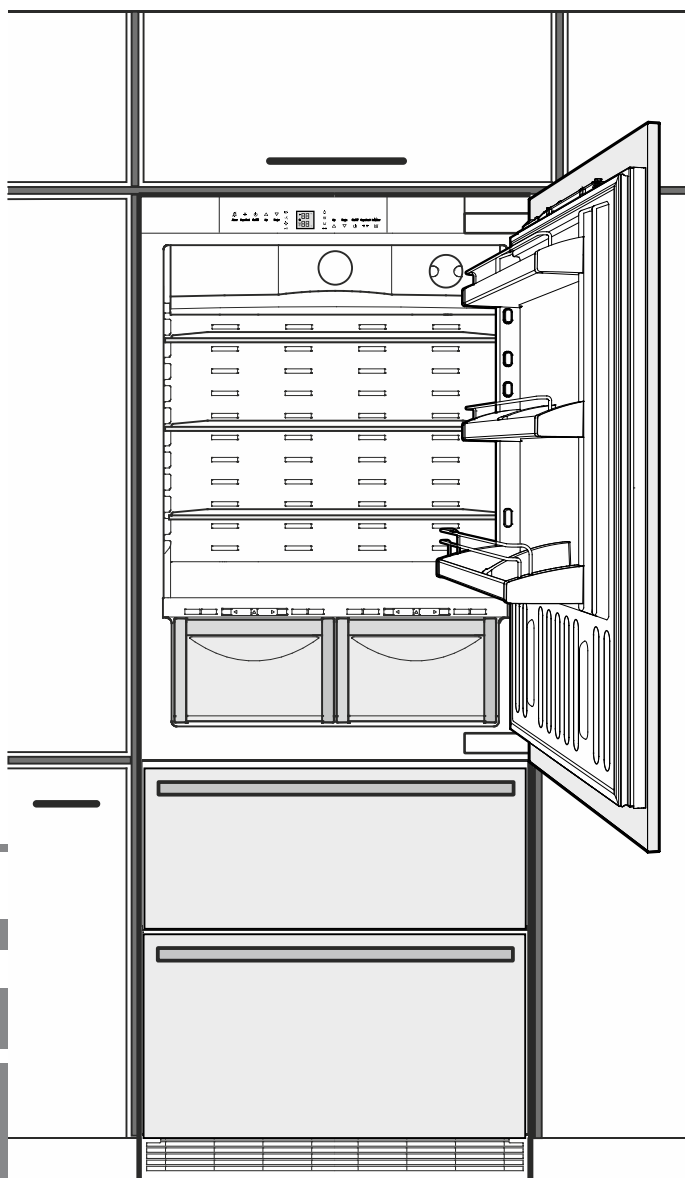

7083 461-00

ECBN 5066

LIEBHERR

Content	Page
Setting up	2
Electrical connection	2
Appliance venting	2
Door swing clearance	2
Appliance dimensions	3
Installation dimensions	3
Mounting the anti-tipping device	4
Mounting options	4
Connection to the water supply	5
Leveling the appliance	7
Fastening the appliance in the recess	7
Adjusting the refrigerator door	7
Adjusting the front of the drawer	7
Mounting the ventilation grille	8
Before fitting the door panels	9
Panel dimensions	9
Mounting the attachment brackets onto the door panels	10
Mounting the refrigerator panel	11
Mounting the freezer panels	13
Changing over door hinges	13

Setting up

- Avoid positioning the appliance in direct sunlight or near cookers, radiators and similar sources of heat.
- The floor on which the appliance stands should be horizontal and level.
- The ventilation grilles should not be obstructed. Always ensure that there is good ventilation and that the outward flowing air is able to escape.
- Standard EN 378 specifies that the room in which you install your appliance must have a volume of 1 m³ per 8 g of R 600a refrigerant used in the appliance, so as to avoid the formation of inflammable gas/air mixtures in the room where the appliance is located in the event of a leak in the refrigerant circuit. The quantity of refrigerant used in your appliance is indicated on the type plate on the inside of the appliance.

Electrical connection

Only operate the appliance with **alternating current (AC)**.

The permissible voltage and frequency are indicated on the type plate. The position of the type plate is shown in the description of the appliance.

The socket must be properly earthed and protected by a fuse.

The tripping current of the fuse must be between 10 A and 16 A.

The socket must not be situated behind the appliance and must be easily accessible.

Do not connect the appliance using an extension cable or extension socket.

Do not use stand-alone inverters (conversion of direct current to alternating/three-phase current) or energy-saving plugs. Risk of damage to the electronic control system!

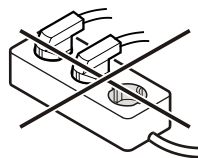

Appliance venting

The required air flow is directed through the plinth.

It is important to use the provided ventilation grille for the ventilation opening.

This opening must not be covered.

Failure to use the supplied grille can result in product failure and will void the warranty.

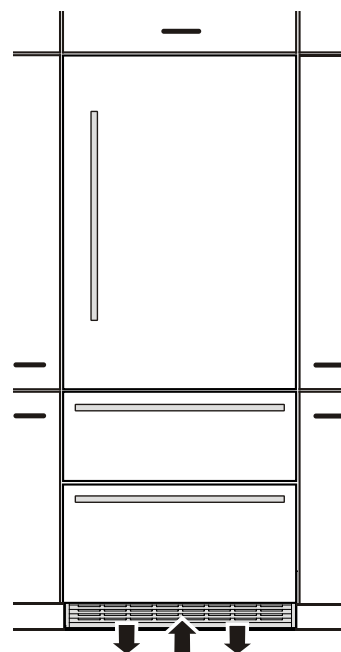

Door swing clearance

Please allow for door swing clearance at locations next to a wall.

The illustrated measurement is without mounted front panels.

Be sure to add your panel thickness and handle depth to this measurement in order to avoid interferences.

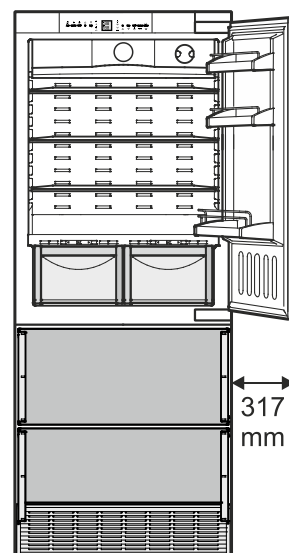

Appliance dimensions

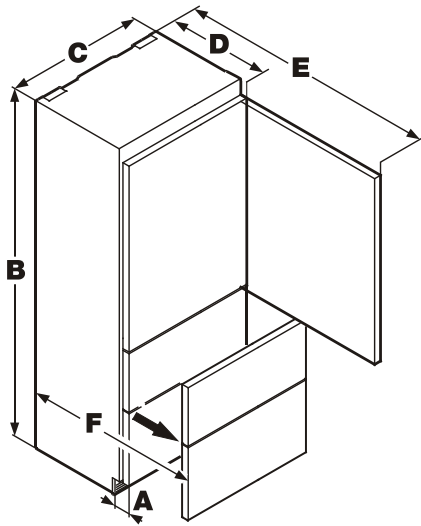

A = 76 mm
 B = 2027 mm
 C = 757 mm
 D = 610 mm
 E = 1403 mm
 F = 943 mm

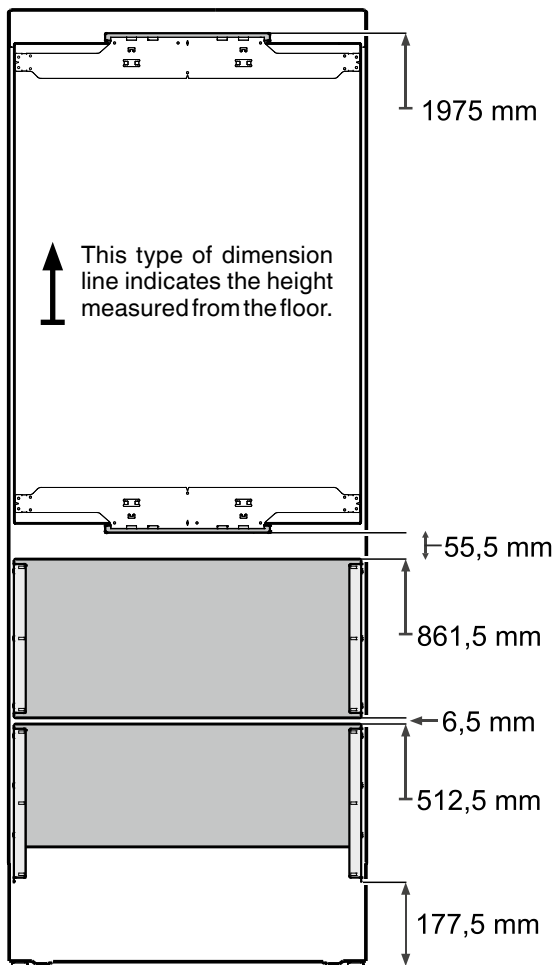

Installation dimensions

The location of the socket can within a radius of 2000 mm from the appliance top center.

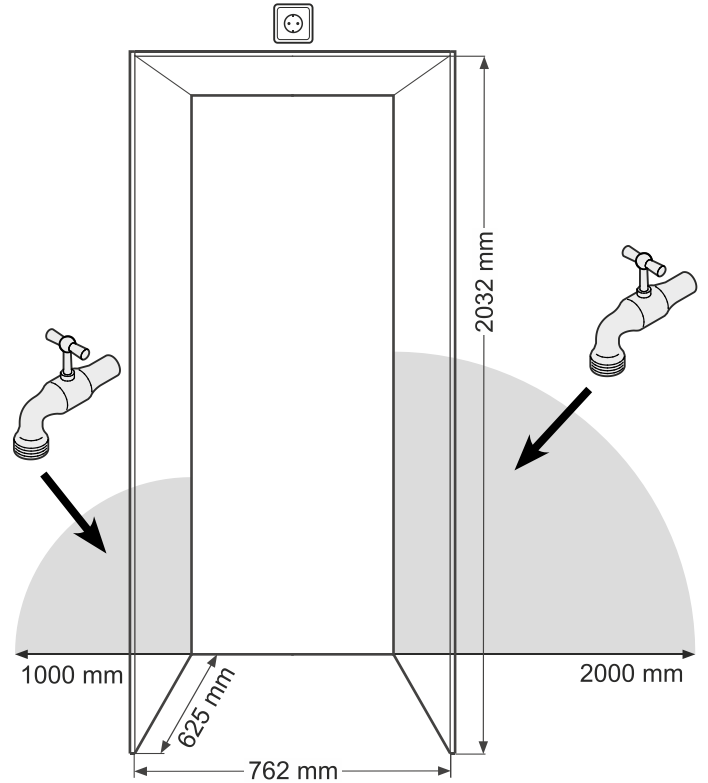

The ice maker is fitted in the freezer compartment of the combined refrigerator-freezer. It must be connected to the mains water supply to work.

The water shut-off valve must be positioned within the areas marked in grey.

Important

Do not install the shut-off valve behind the appliance.

⚠ WARNING!

The water shut-off valve must not sit directly above the socket!

The gap between the water shut-off valve and the socket must comply with the regulations of the country in which the appliance is used!

Mounting the anti-tipping device



WARNING!

The supplied anti-tipping bracket must be installed in all cases. This prevents the appliance from tipping over when the fully loaded door is opened.

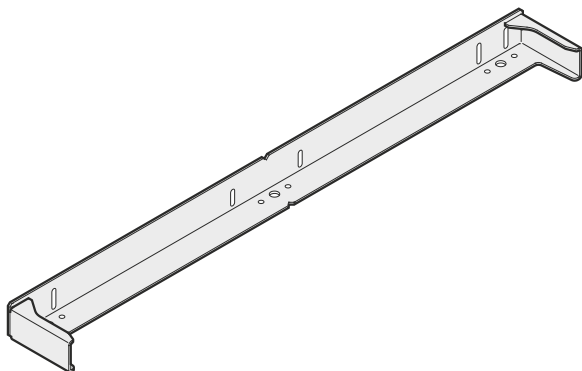

CAUTION!

Ensure that there are no electric cables or water pipes in the wall section to which the anti-tipping bracket is to be secured. These could be damaged during installation.

Installation:

1. Mark the centre line of the appliance on the floor.
Align the anti-tipping bracket centre to the centre line.
2. Depending on the constitution of the floor and wall, use any possible mounting option as shown in chapter **Mounting Options**.
The screws (6 x 60) are supplied with the accessory pack.

Important!

If the floor slopes down sideways, the anti-tipping bracket must be fitted horizontally. Lay down spacers in the appropriate positions.

Mounting options

Mounting the bracket with the wall studs.

Mounting with plugs to concrete walls.

3 Screws 6 x 60 mm

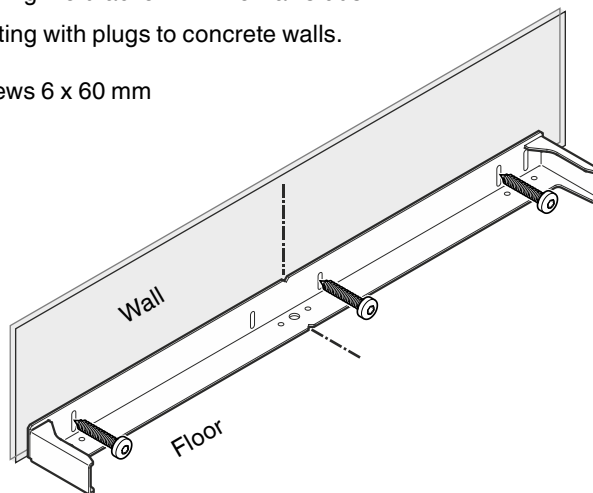

Mounting with the wall plate turning in the screws at an angle.

3 Screws 6 x 60 mm

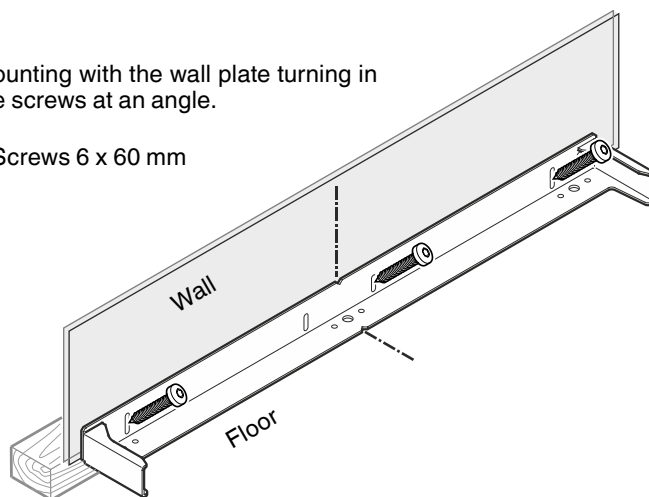

Mounting with wooden floors.

Mounting with plugs to concrete floors.

3 Screws 6 x 60 mm

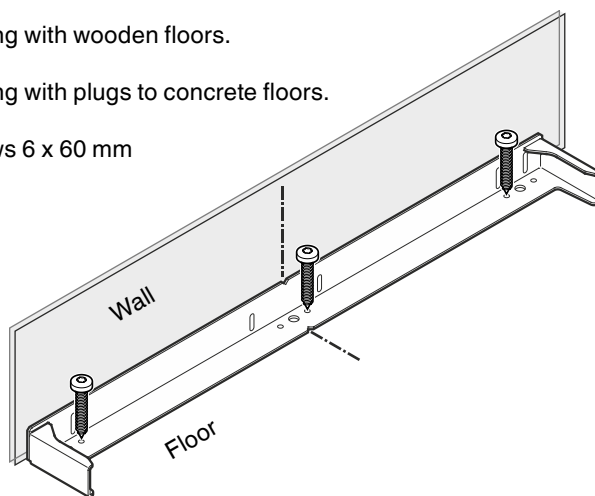

Connection to the water supply

Safety instructions and warnings

- Do not connect to the water supply while the combined refrigerator-freezer is connected to the electricity supply.
- **The connection to the mains water supply may only be made by trained personnel.**
- **The water quality must comply with the drinking water directives of the country in which the appliance is used.**
- The ice maker is designed exclusively to make ice cubes in quantities required by a household and may only be operated with water suitable for this purpose.
- All repairs and work on the ice maker may only be carried out by customer service personnel or other trained personnel.
- **The manufacturer cannot accept liability for damage caused by a faulty connection to the mains water supply.**

Water pressure

The **water pressure** must be between **0.15 and 0.6 MPa (1.5 - 6 bar)**.

Important:

If the water filter is inserted in the appliance, the **water pressure** must lie between **0.3 and 0.6 MPa (3 - 6 bar)**. If the water pressure with the inserted water filter is too low, this may cause the ice maker to malfunction.

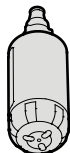

The water supply to the appliance must be through a cold water pipe that can withstand the operating pressure and complies with the hygiene regulations. For this, use the stainless steel hose supplied (length 3 m).

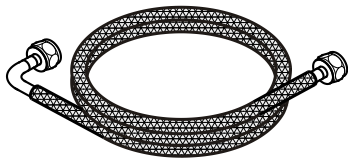

Installation

1. Place the appliance in front of the installation recess.

2. Apply cover strips above, between and below the securing plates on the side walls of the appliance.

Cut the cover strips to the right length for this purpose.

Fit the adhesive cover strips leaving a gap of 6,5 mm to each securing plate. This ensures problem-free fitting of the covers.

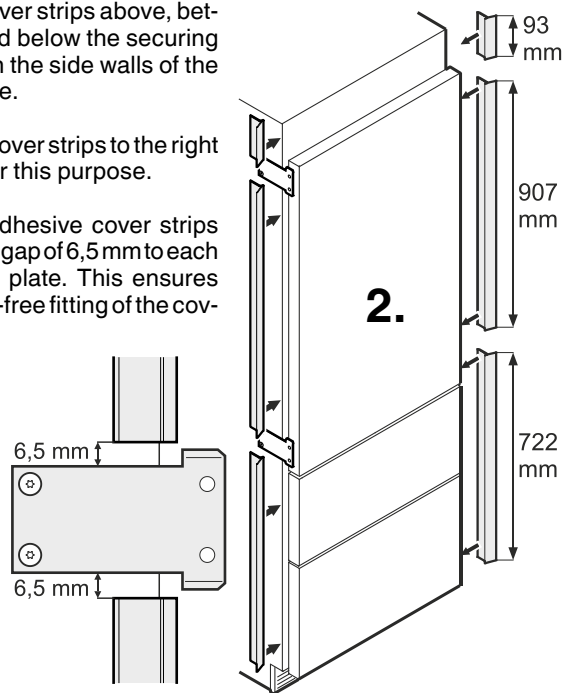

3. Insert the bent section of the hose through the opening at the right side of the appliance.

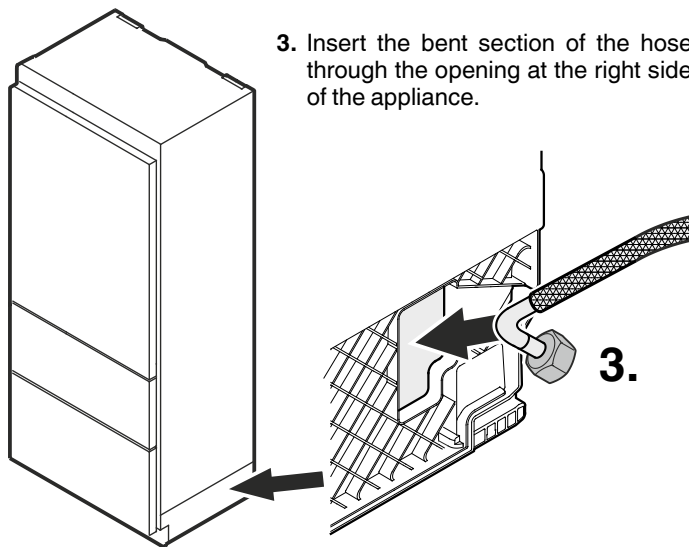

4. Move the hose to the front and connect with the valve connector.

Be sure the connection is tightly arranged.

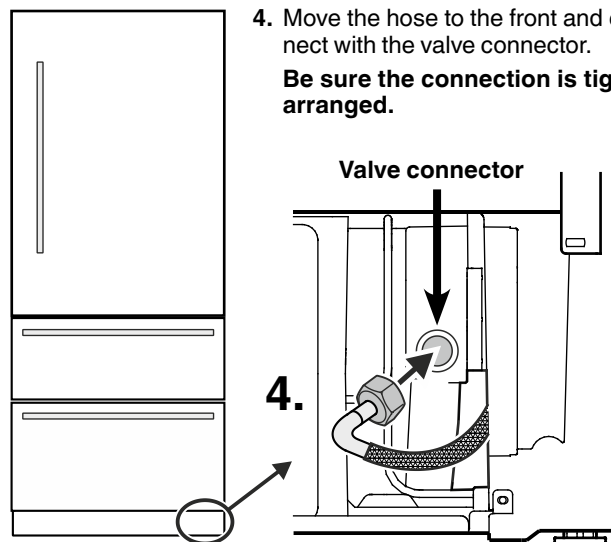

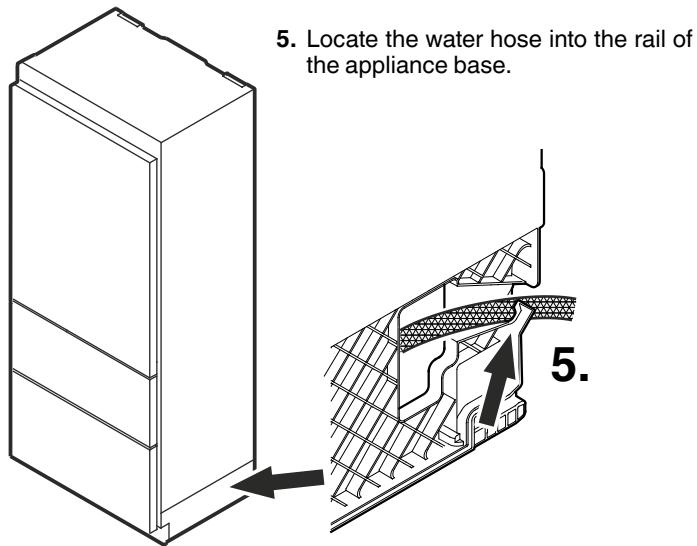

8. Push the appliance slowly into the recess until the compressor mounting plate touches the anti-tipping bracket.

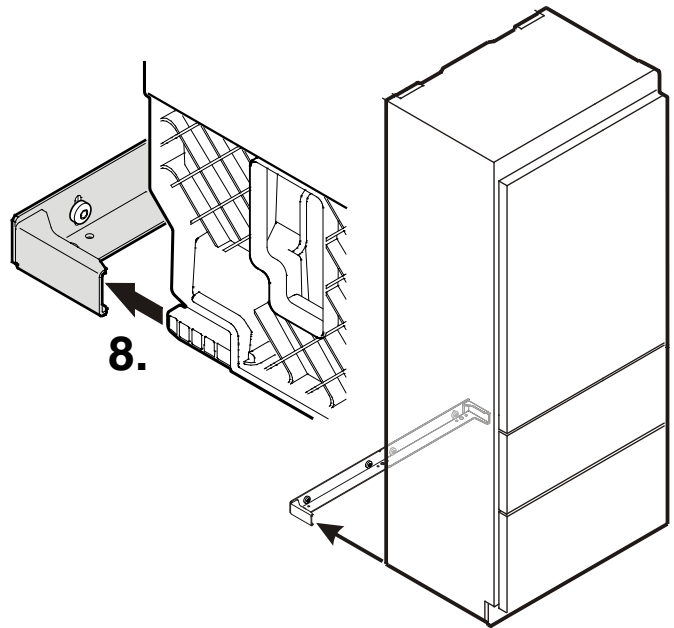

6. Route the mains cable towards the socket.

7. Route the water hose towards the water shut-off tap.



WARNING!

Do not connect the appliance to the power supply until the installation is completed.



CAUTION!

Lay the mains cable and the water hose in such a way that they will not be damaged when the appliance is slid into the installation recess.

9. Fill the hose with water and connect to the shut-off tap.

Be sure the connection is tightly arranged.

Open the shut-off tap and check the system for leakage.

Important!

After the ice maker has been switched on, the water supply system must be bled. See the section **Bleeding the ice maker** in the operating instructions.

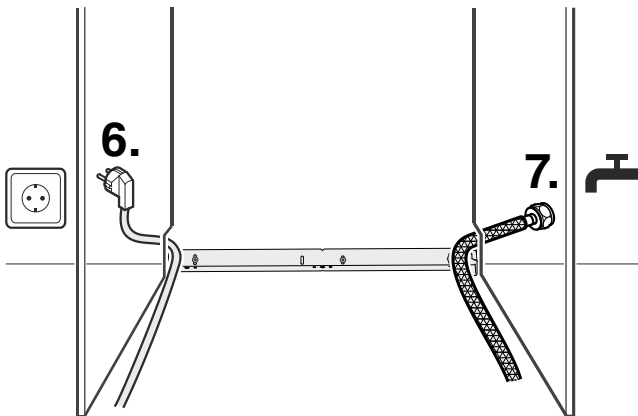

Leveling the appliance

1. Adjust the height of the appliance at the front by twisting the leveling feet ①. Use the open-ended spanner provided. Turn the spanner counterclockwise to raise the appliance front and clockwise to lower it. Position the spanner accordingly (①).
2. Adjust the height of the appliance at the rear by turning the adjusting bolts ②. Use a 1/4" box spanner or the Torx 25 wrench provided.
3. Rotate leveling feet ① until firmly in place against the floor.

⚠ WARNING!

To prevent the appliance from tipping forward the leveling feet ① must have contact with the floor.

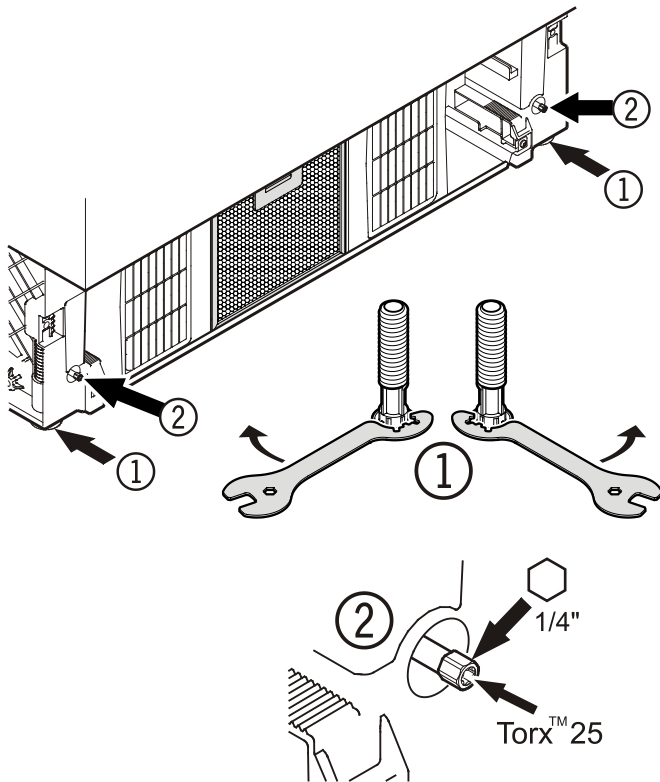

Fastening the appliance in the recess

Once in the recess, secure the appliance to the body of the unit using the securing plates (4 x 16 screws).

Then click the covers supplied into place.

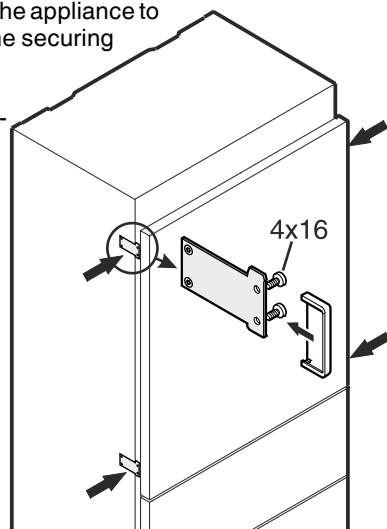

Adjusting the refrigerator door

The lateral tilt of the refrigerator door can be adjusted if required. Undo screws ①. Adjust the lateral tilt using the grub screw ② (Allen key A/F 2.5).

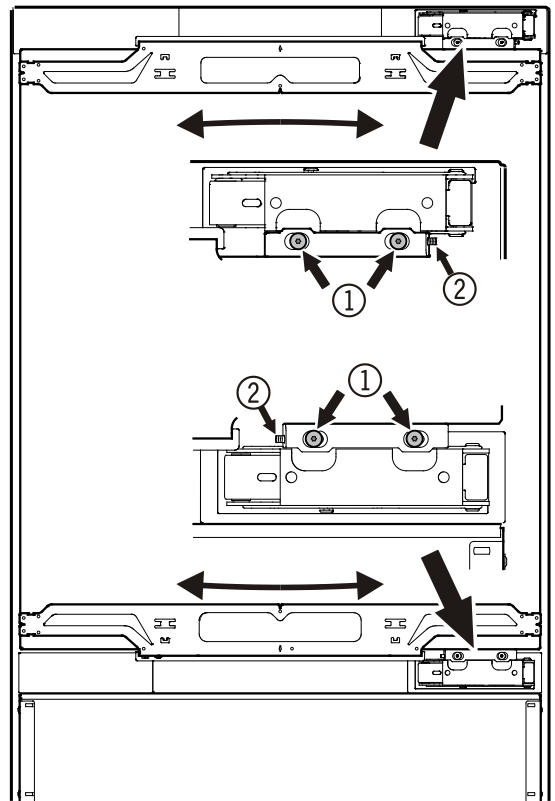

Adjusting the front of the drawer

If required, the front of the freezer drawers can be adjusted.

Transfer the screws shown in the illustration (on the left and right sides of the freezer drawer) individually to the long slots below.

Tighten the screws in the front of the drawer once it is in the right position.

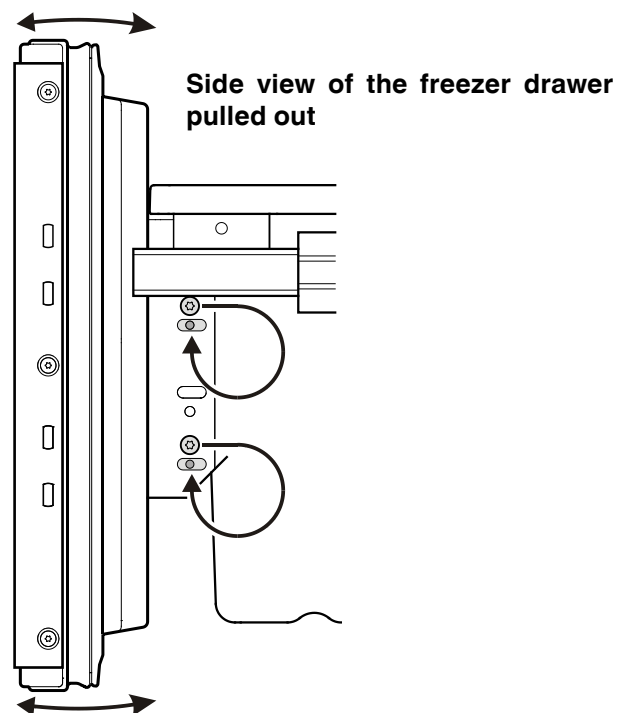

Mounting the ventilation grille

Pull out the bottom freezer drawer.

1. Remove the blue protection film from the dust filter provided and insert the filter into its opening in the plinth. Engage the filter at the bottom, press down the button and click into place.

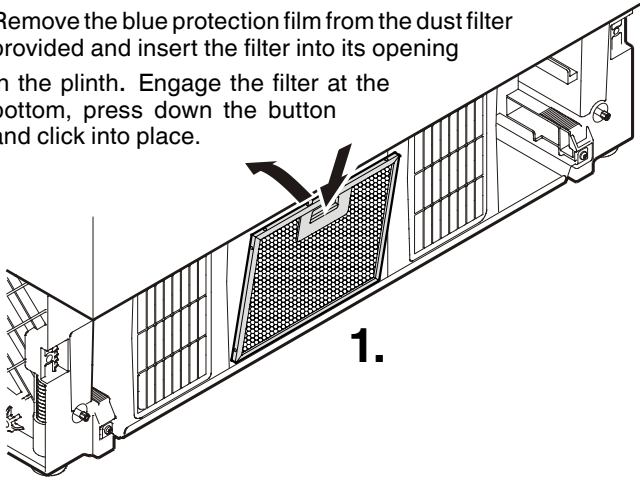

2. Remove the locking pins of both supports. The supports are provided with the appliance accessory pack.

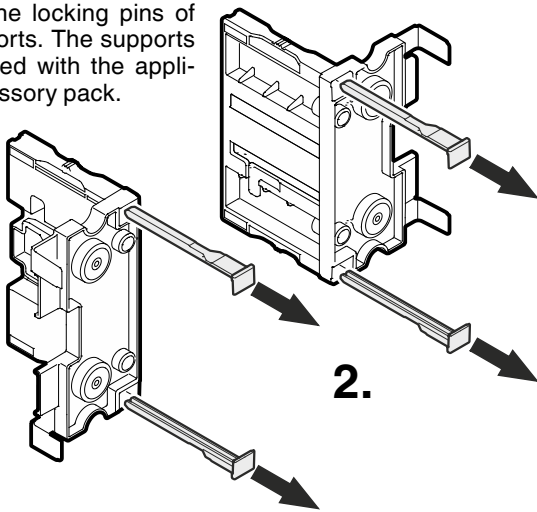

3. Insert the supports for the ventilation grille on the left and right sides in the motor compartment.

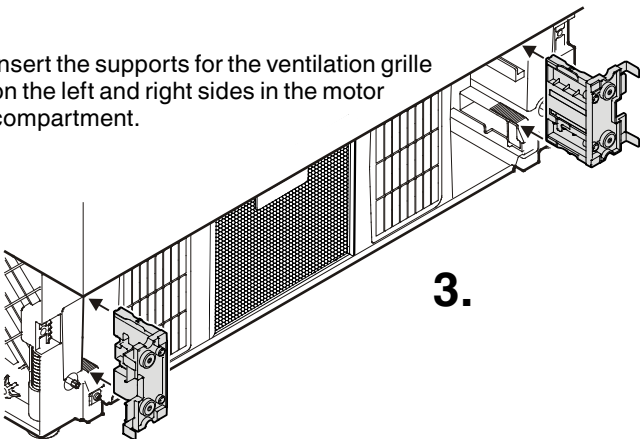

4. The front edge of the brackets is flush with the front of the ventilation grille. Adjust the supports accordingly.

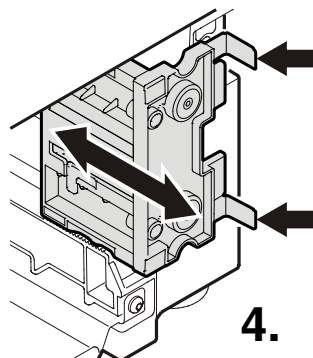

5. Insert the locking pins to block the supports.

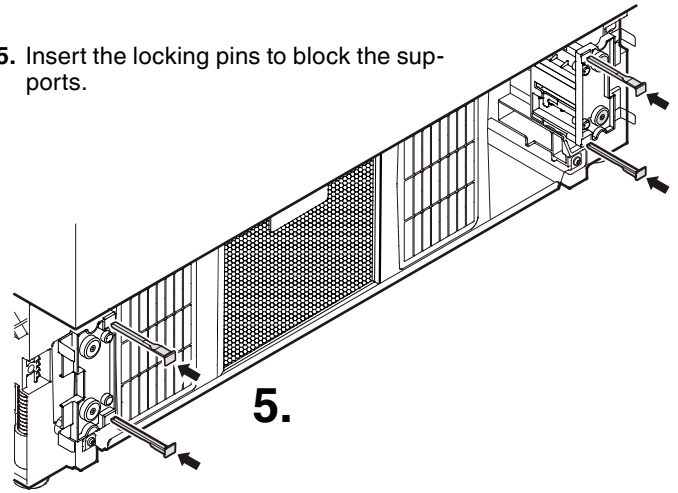

6. Install the ventilation grille.

The grille has bolts on the inside (see detail in the drawing below). These bolts must be inserted into the holes of the supports.

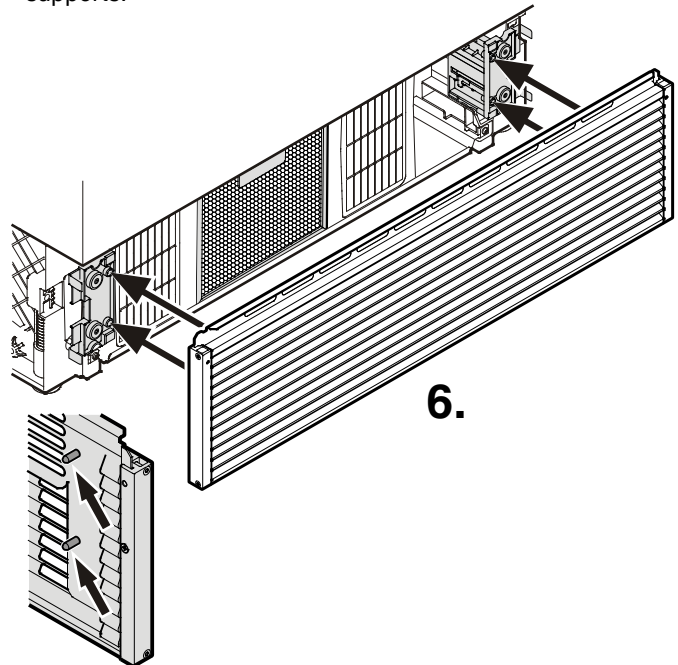

7. Adjust the height of the ventilation grille.

- Loosen the grub screws at the front of the grille (Allen key A/F 2.5).
- Adjust the ventilation grille to the desired height.
- Tighten the grub screws.

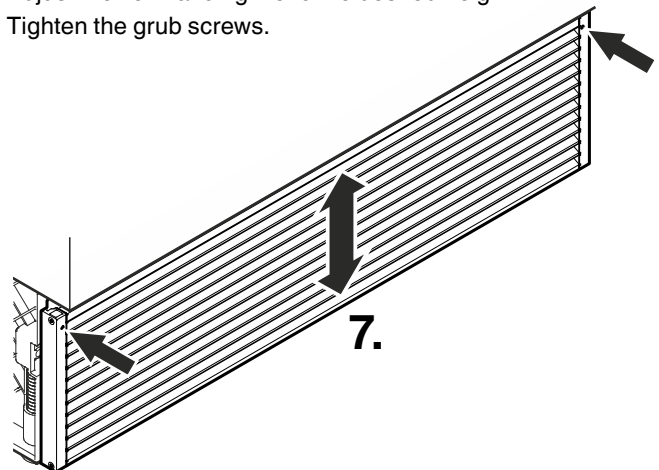

Before fitting the door panels

Remove the cover ① and unscrew the top and bottom attachment brackets ② from the refrigerator door. These attachment brackets will be mounted onto the refrigerator door panel.

Important!

The securing nuts are needed for re-mounting the pre-assembled door panel onto the refrigerator door.

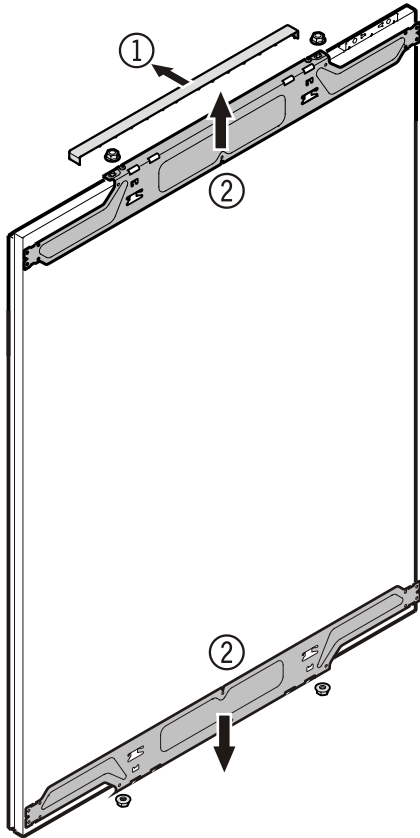

Unscrew the attachment brackets ③ from the freezer drawers. These attachment brackets will be mounted onto the freezer panels.

Important!

The screws are needed for re-mounting the pre-assembled freezer panels onto the freezer drawers.

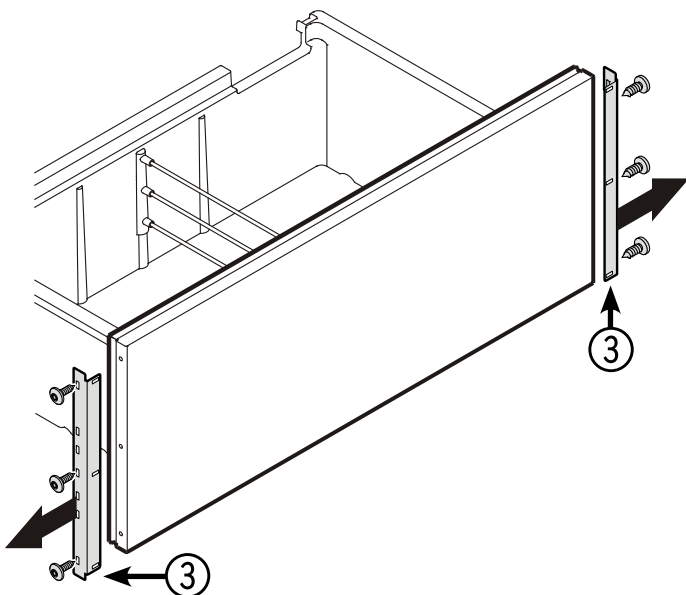

Panel dimensions

Min. panel thickness = 16 mm
Max. panel thickness = 19 mm

Maximum panel weight

Refrigerator panel = 27 kg
Freezer drawer panel = 10 kg

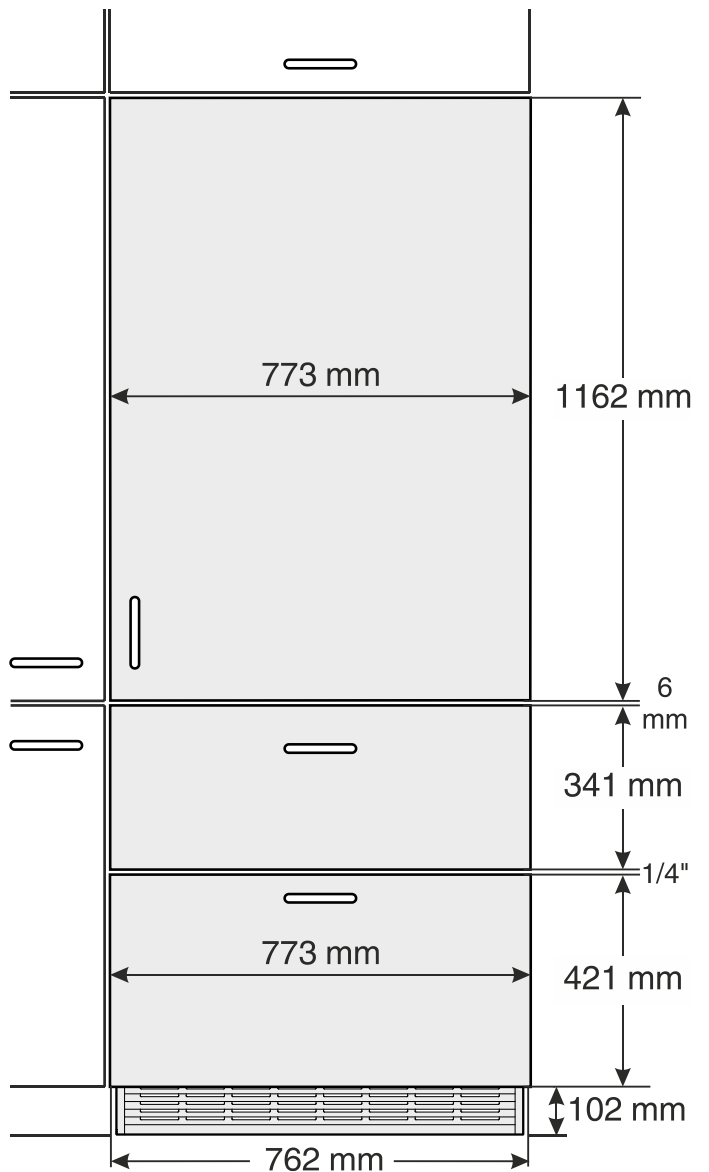

Mounting the attachment brackets onto the door panels

1. Draw a line 1041 mm from the bottom side of the door panel.
2. Draw a further line 107.5 mm from the bottom side of the door panel.
3. Align one of the refrigerator door attachment brackets to the top line, as shown in the illustration below, and secure with at least 6 screws (4 x 14).
4. Align the second refrigerator door attachment bracket to the bottom line, as shown in the illustration below, and secure with at least 6 screws (4 x 14).
5. Secure each of the attachment brackets that have been removed from the freezer drawers using 3 screws (4 x 14), as shown in the illustration below.

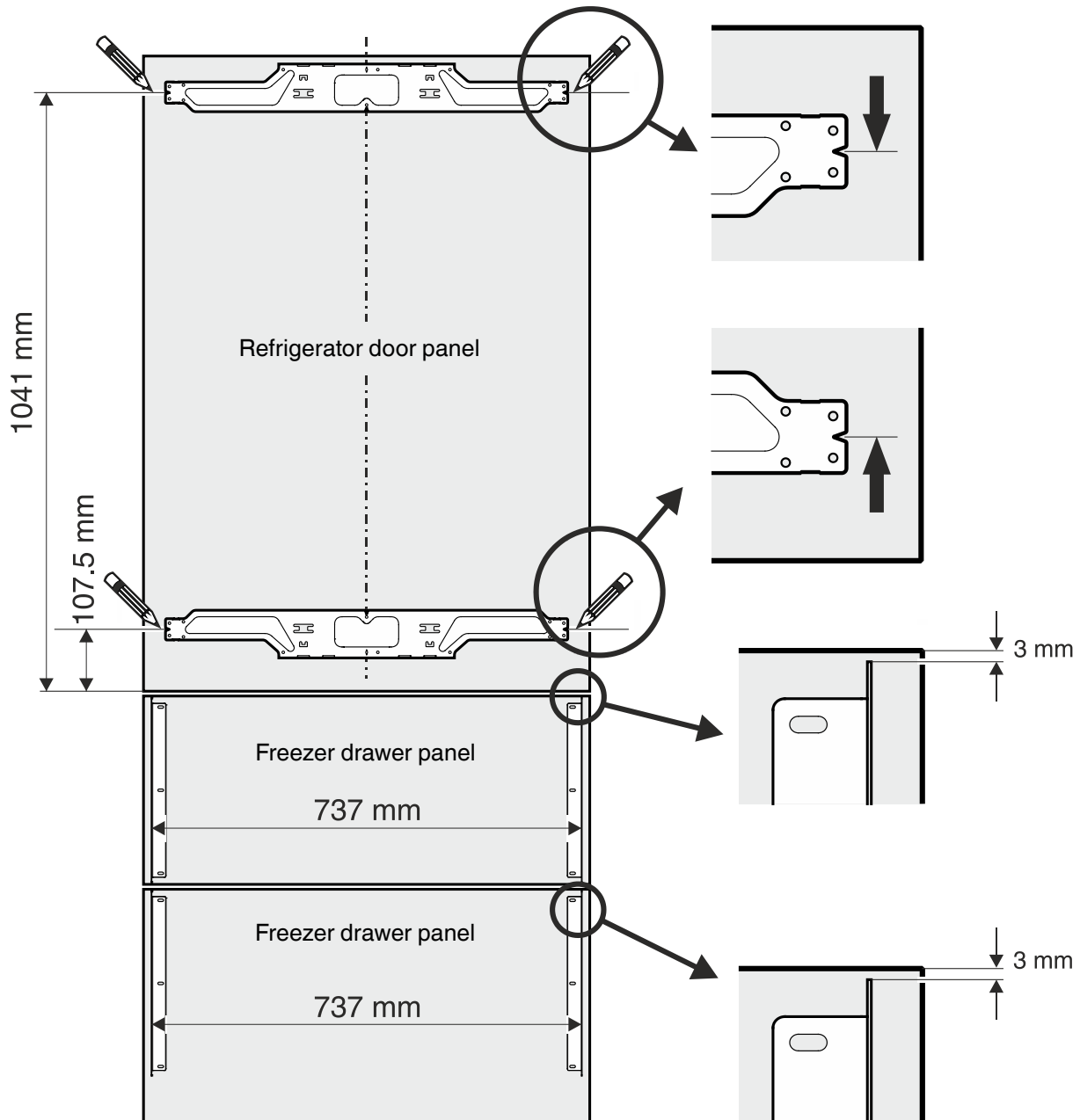

Mounting the refrigerator panel

1. Screw in the adjusting pins on the underside of the refrigerator door completely (**fig. A**).

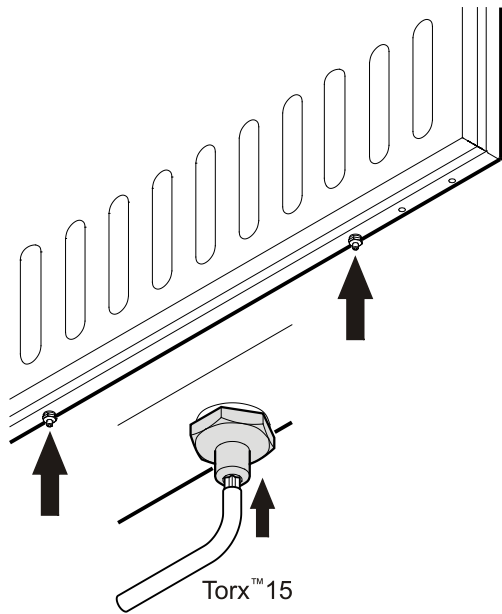

fig. A

2. Open the refrigerator door and suspend the refrigerator panel on the top adjusting pins (**fig. B**).
3. Screw securing nuts onto the adjusting pins and slightly tighten.

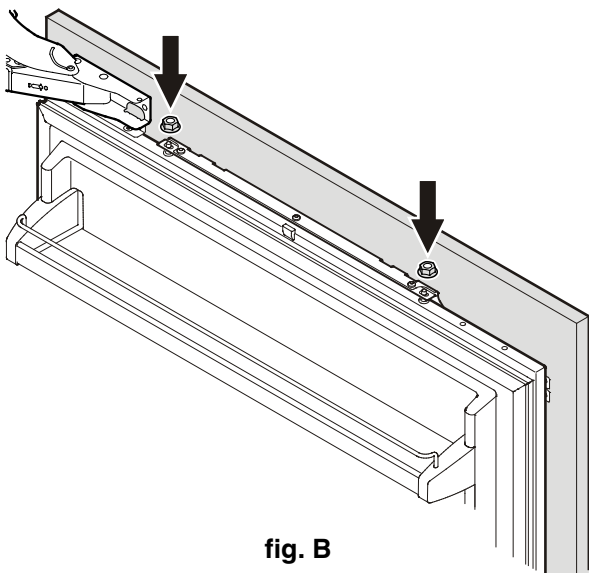

fig. B

4. Close the refrigerator door and check the height of the panel.
5. Adjust the height of the panel if necessary. Undo the securing nuts and use the adjusting pins to adjust (**fig. C**).

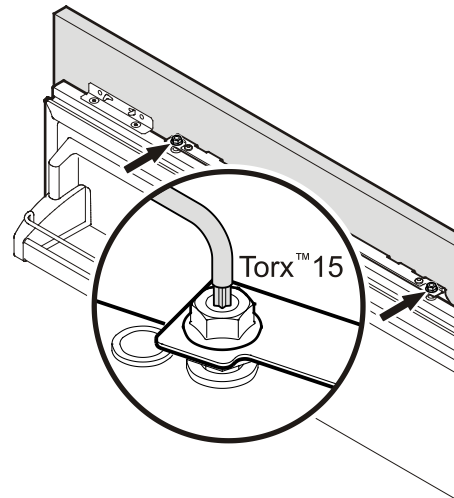

fig. C

6. Adjust the panel horizontally (using the long slots in the attachment bracket) (**fig. D**).
7. Tighten the securing nuts.

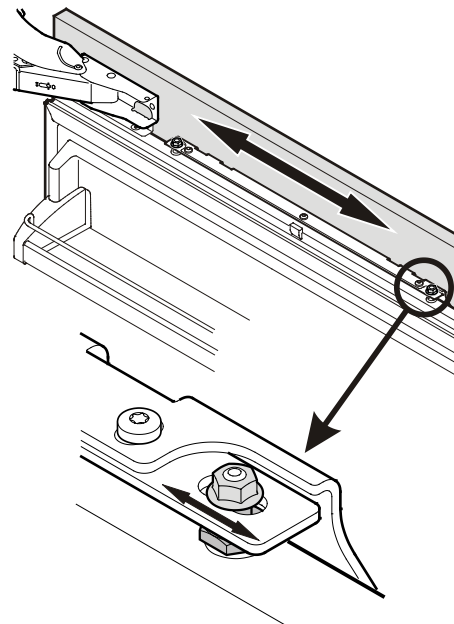

fig. D

8. Remove the adjusting pins (bottom of the refrigerator door) until these touch the attachment bracket (**fig. E**).

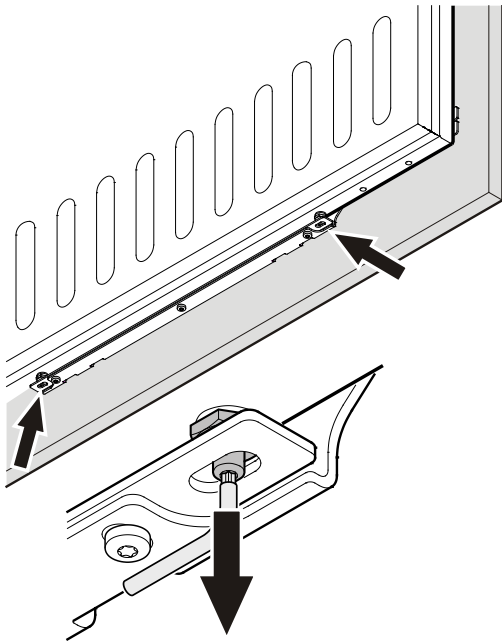

fig. E

9. Screw on the securing nuts and tighten (**fig. F**).

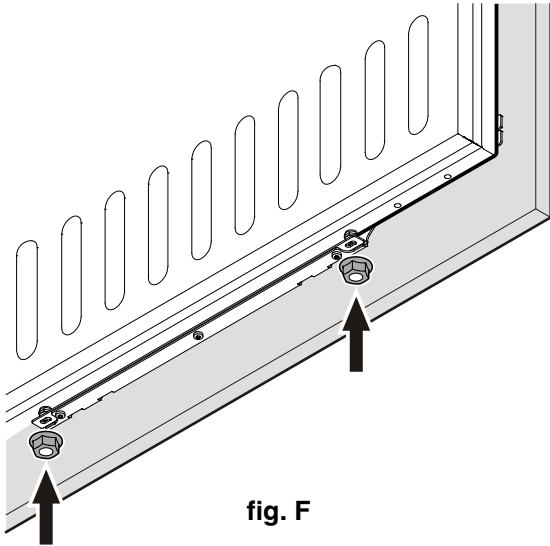

fig. F

10. Undo the three screws on the top of the attachment bracket, adjust the door panel as displayed in **fig. G** and then retighten the screws. The same procedure can be carried out for the bottom attachment bracket.

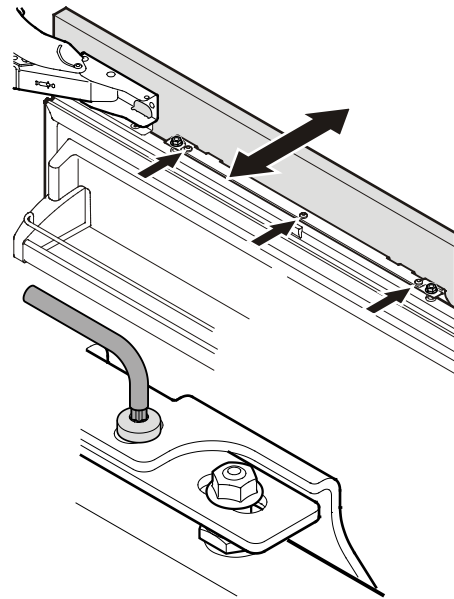

fig. G

11. Click the top and bottom covers into place ① (**fig. H**)

Insert the cover strip provided ② between refrigerator door and panel.

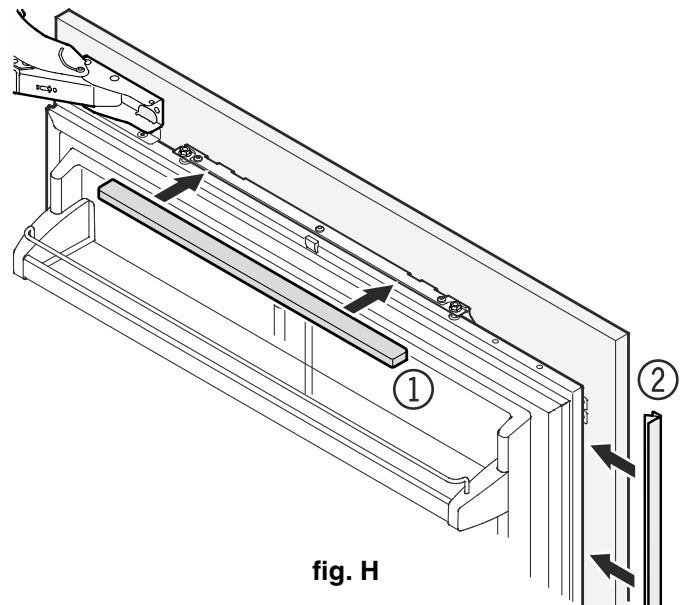
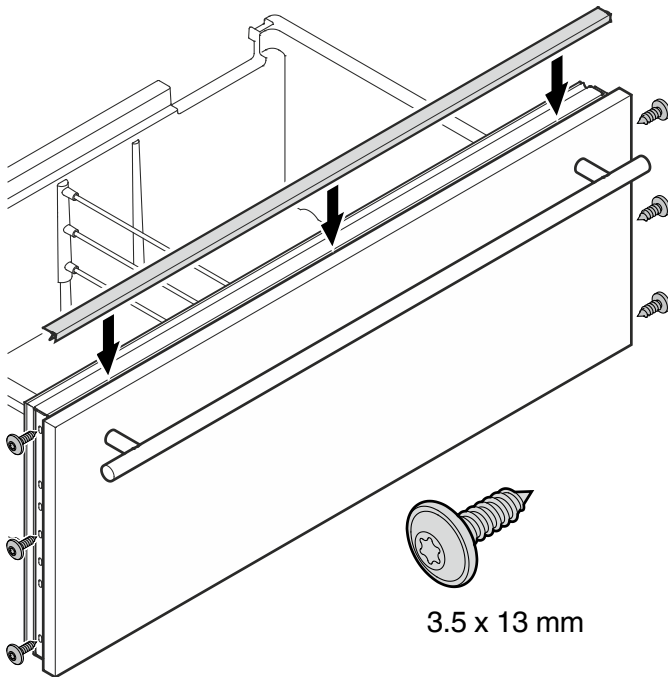

fig. H

Mounting the freezer panels

1. Pull out the top freezer drawer and screw on the pre-assembled panel. The same screws must be used as those used to screw on the attachment brackets (3.5 x 13).
2. Close the freezer drawer and check the position of the panel. Adjust the height of the panel by undoing the left and right screws. Tighten the screws.
3. Pull out the bottom freezer drawer and mount the panel in the same way.
4. For both drawers, cover the gap between the drawer and the panel with the cover strips supplied. Remove the protective film from the trim and insert into the gap at the top.



Changing over door hinges

Door hinges should only be changed by a trained expert.

⚠ WARNING!

Do not try to change over the door hinges yourself. The refrigerator door hinges are fitted with strong closing springs. If the hinge accidentally snaps shut, this can lead to serious injury.

